

# United States Court of Appeals for the Federal Circuit

00-1571  
(08/455,374)

IN RE FRANK S. GLAUG  
and MARGARET A. KATO,

Meredith Martin Addy, Brinks, Hofer Gilson & Lione, of Chicago, Illinois, argued for appellants. With her on the brief were Robert N. Carpenter and Henry L. Brinks.

Linda Moncys Isacson, Associate Solicitor, Office of the Solicitor, Patent and Trademark Office, of Arlington, Virginia, argued for appellee. With her on the brief was John M. Whealan, Solicitor, and Mary Critharis, Associate Solicitor.

Appealed from: United States Patent and Trademark Office  
Board of Patent Appeals & Interferences.

# United States Court of Appeals for the Federal Circuit

00-1571  
(Serial No. 08/455,374)

IN RE FRANK S. GLAUG  
and MARGARET A. KATO

---

DECIDED: March 15, 2002

---

Before MAYER, Chief Judge, NEWMAN and MICHEL, Circuit Judges.

NEWMAN, Circuit Judge.

Frank S. Glaug and Margaret A. Kato (herein "Glaug") appeal the decision of the Board of Patent Appeals and Interferences of the United States Patent and Trademark Office, rejecting all of the claims of patent application Serial No. 08/455,374 entitled "Process for Making a Training Pant Having a Unitary Waist Elastic System." The Board's decision is reversed.

The Glaug invention is a method of making disposable training pants. The pants are described as providing a more comfortable fit over a wider weight and size range as well as

a longer useful life, as compared with known training pants, because the elasticity at the waist is preserved over a longer period of repeated cycles of elastic extension and contraction, such as when the child lowers and raises the pants. These benefits result from the manner in which the elastic is adhered at the waist, achieved by placing the adhesive that holds the elastic in spaced zones so that there are zones wherein the fabric is unadhered between the adhesive zones, and folding the edge of the fabric over the elastic.

Claim 1, the broadest claim, is representative. Emphases have been added to the features asserted by Glaug to provide distinction from prior art processes:

1. A process having a machine direction and a cross direction for making disposable absorbent articles, comprising the steps of:
  - [a] continuously moving a base layer generally in a machine direction, the base layer comprising opposite edge portions generally extending in the machine direction,
  - [b] providing a plurality of absorbent structures having respective length dimensions greater than respective width dimensions,
  - [c] positioning the absorbent structure at spaced apart locations between the opposite edge portions of the base layer, such that the length dimensions of the absorbent structure are generally transverse to the machine direction,
  - [d] applying an adhesive, generally in the machine direction, at **selected spaced apart zones of each edge portion, the zones of each edge portion being spaced apart in the machine direction,**
  - [e] continuously delivering an elastic member generally in the machine direction onto each edge portion,
  - [f] **folding each edge portion, generally in a cross direction, over the respective elastic member,**
  - [g] joining together each folded edge portion and the elastic member,
  - [h] folding the continuously moving base layer along a fold line generally parallel to the machine direction, and
  - [i] forming a plurality of disposable absorbent articles having a respective plurality of closed-loop waist-elastic systems in which each waist elastic system has an **average maximum magnitude of decay less than about 66.67 grams in an extension range of about 175 millimeters to about 300 millimeters over the first three cycles.**

The placement of the adhesive is illustrated in the following diagram of the construction process:

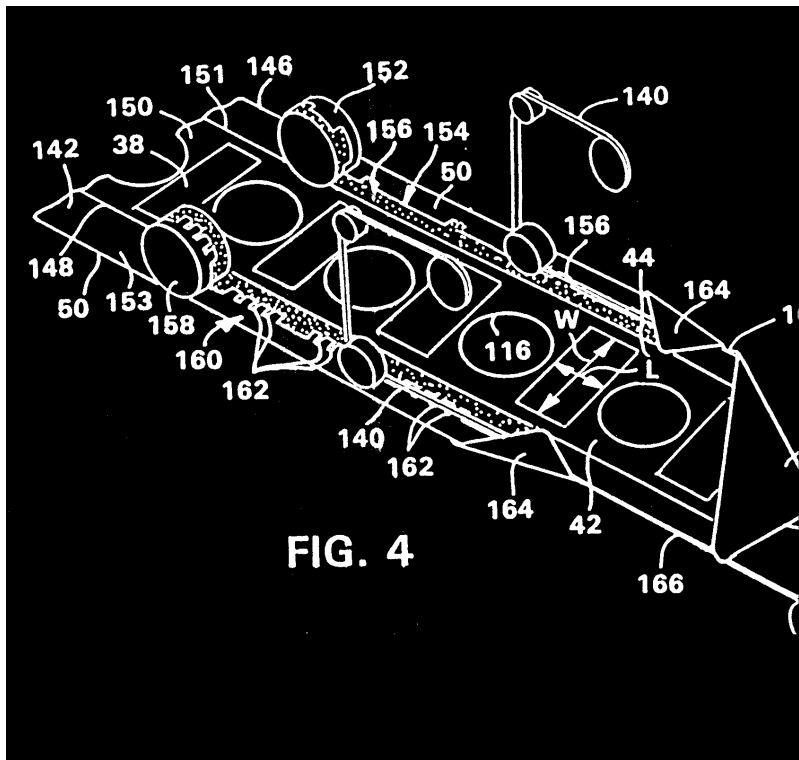

Figure 4 shows a process for making one embodiment of the pant. As base layer 142 is continuously moved through the machine, absorbent structures 38 are attached and leg openings 116 are cut. To form the waist elastic system, adhesive is applied by means of patterned adhesive rolls 152 and 158. Glaug explains that different adhesive patterns are shown on rolls 152 and 158 to illustrate different possible patterns, but that generally the patterns are the same on both sides of the base layer. The adhesive 154 is thus applied in a pattern, which includes a plurality of distinct adhesive zones 156 and 162 which are spaced apart from one another. An elongate elastic member 140 is joined to the adhesive zones 156 and 162. The remaining adhesive, as at 154, serves to join the folded-over edge of the base layer 142 after it passes folding boards 164. The structure is then folded down its center, cut at the leg openings, and sealed to form pants.

### ***The PTO Proceedings***

During patent examination the PTO bears the initial burden of presenting a prima

facie case of unpatentability. In re Oetiker, 977 F.2d 1443, 1445, 24 USPQ2d 1443, 1444 (Fed. Cir. 1992); In re Piasecki, 745 F.2d 1468, 1472, 223 USPQ 785, 788 (Fed. Cir. 1984). If the PTO fails to meet this burden, then the applicant is entitled to the patent. However, when a prima facie case is made, the burden shifts to the applicant to come forward with evidence and/or argument supporting patentability. Patentability vel non is then determined on the entirety of the record, by a preponderance of evidence and weight of argument. Id. As discussed in In re Rinehart, 531 F.2d 1048, 1052, 189 USPQ 143, 147 (CCPA 1976), the prima facie case is not a stone wall against which rebuttal evidence is tested; patentability is determined by a preponderance of all the evidence. We review the Board's decision on the record, in accordance with the appellate criteria of the Administrative Procedure Act, 5 U.S.C. §706. See Dickinson v. Zurko, 527 U.S. 150, 50 USPQ2d 1930 (1999).

The examiner rejected all of the claims on the ground of obviousness, based on United States Patent No. 5,147,487 (Nomura) in view of United States Patent No. 3,225,765 (Magid). Both references relate to disposable baby pants. The Nomura reference shows a method having the steps of Glaug's claim 1 except for those shown supra in bold face. Magid shows a fold or hem of fabric over the elastic at the waist and legs of baby pants. The Board found that Nomura suggested "intermittent" spacing of the adhesive for the elastic waist, that the numerical magnitude of elastic decay as stated in claim 1 is inherent in the Glaug structure and thus not of patentable significance, and that it would have been obvious to place the Magid hem over the Nomura elastic. The Board held that a prima facie case of obviousness was made, and that Glaug's evidence of superior results was inadequate to rebut that conclusion.

***Claim Clause [d] - The Spaced Apart Adhesive Zones***

Claim clause [d] states that the adhesive is applied "generally in the machine direction" in "zones" that are "spaced apart." The specification explains that the adhesive may be placed only on the seams with the elastic secured when the halves of the folded-over pant are joined together, or may be spaced more closely along the elastic with as little as half-inch gaps between zones of adhesive. Nomura describes and illustrates, in the preferred embodiments, applying the adhesive to the pant edges in a continuous film. Nomura also states that "the adhesive zones may be applied with adhesive continuously extending overall on these zones, or in a plurality of dots, intermittent lines, or helical lines."

The Board held that this was a prima facie teaching of Glaug's "spaced apart" adhesive zones, in that Glaug's placement of adhesive in zones is taught by or would have been obvious from the Nomura reference. The Board pointed out that both Nomura and Glaug use the word "intermittent" in describing the adhesive.

Glaug argues that Nomura's illustrations do not show intermittent zones of adhesive, and that the only usage of "intermittent" by Nomura is in one broad catch-all sentence at the end of the description. Glaug argues that Nomura clearly did not contemplate spaced zone-type gaps in the adhesive placement in the machine direction. Glaug points to the following illustration from Nomura, and argues that Nomura does not show adhesive placed in zones that are separated by adhesive-free zones:

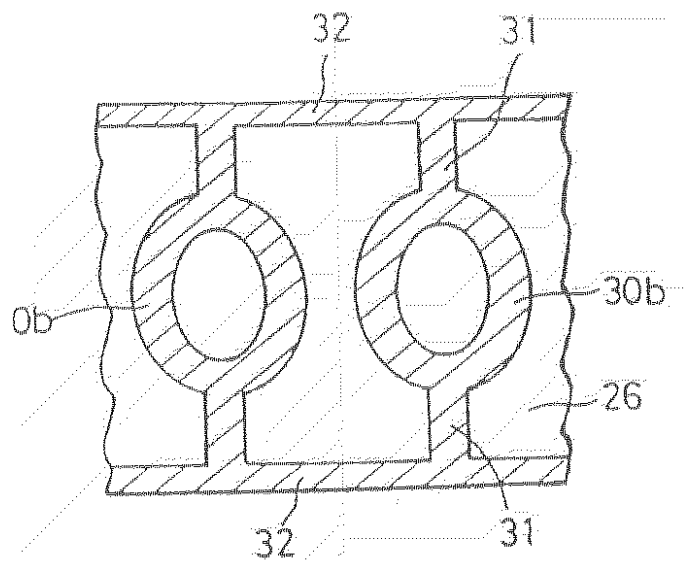

In Nomura, the pants are formed by spreading adhesive upon a continuous web 26, formed of fibrous non-woven fabric, introducing elastic members (not shown) and bonding the arrangement to another continuous web, sandwiching absorbent material within. The diagram reproduced shows the placement of adhesive at 30b around the leg openings, at 32 along the waist, and at 31 extending from opposite sides of adhesive 30b to the adjacent lateral edges of the web 26.

Glaug also points out that Nomura adheres the elastic in an entirely different way from the Glaug process: Nomura stretches the elastic, and applies the adhesive to the fabric in a broad band in order to hold the elastic in the stretched position during the manufacturing process. Glaug points out that the Nomura adhesive must be placed so that it provides a large surface area and continuous attachment between the elastic and the fabric. In contrast, the Glaug specification is explicit that the adhesive is applied so as to reduce the area of attachment between the elastic and the fabric, so that zones of fabric are

not adhered to the elastic and can bunch or stretch between the points of adhesion.

Glaug is correct that the Nomura usage of "intermittent" does not suggest the presence of zones entirely free of adhesive and disposed generally in the machine direction. Nomura's specification makes clear that his process requires broad contact between the elastic and the adhesive, with illustrations of continuous zones of adhesive that fix the fabric to the stretch elastic. In contrast, Glaug's specification uses "intermittent" to designate only distinct zones of adhesive spaced apart by zones free of adhesive. Typical descriptions from Glaug's specification are:

The intermittent pattern of joining is a pattern of 1.27 centimeter (0.5 inch) wide adhesive zones separated by 1.27 centimeter wide zones with no adhesive. [Application p. 31.]

[P]ulsed adhesive system 90 can apply an adhesive pattern such as an adhesive zone 92 (Fig. 5) having a window 93 that is void of adhesive. [Application p. 42.]

Adhesive pattern 154 includes a plurality of distinct adhesive zones 156 which are spaced apart from one another, i.e., intermittently applied, in the machine direction 144. [Application pp. 48-49.]

Patterned adhesive roll 158 applies an optional adhesive pattern 160 having a plurality of spaced-apart distinct adhesive zones 162. [Application p. 49.]

The Solicitor cites Glaug's statement that the adhesive roll applies adhesive "intermittently . . . in [the] machine direction [to include] a plurality of distinct adhesive zones 156 which are spaced apart from one another, i.e., intermittently applied," as showing that Glaug himself taught that "spaced apart" and "intermittent" have the same meaning. Glaug responds that his meaning of "intermittent" is as described in the specification, which defines what Glaug meant. Glaug states that "intermittent," in his method, means that the adhesive zones are separated by zones of no adhesive, and thus is distinguished from overlapping strips of adhesive as found in Nomura. Although the Solicitor states that "Nomura expressly



teaches 'applying an adhesive' in 'spaced apart zones,'" PTO brief at 14, these words are quoted from Glaug, not Nomura.

It is well established that when a general term is used to introduce a concept that is further defined more narrowly, the general term must be understood in the context in which the inventor presents it. Multiform Desiccants, Inc. v. Medzam, Ltd., 133 F.3d 1473, 1477, 45 USPQ2d 1429, 1432 (Fed. Cir. 1998) ("This rule of construction recognizes that the inventor may have imparted a special meaning to a term in order to convey a character or property or nuance relevant to the particular invention.") The word "intermittent" is susceptible of various meanings, and the inventor's lexicography must prevail, Intellicall, Inc. v. Phonometrics, Inc., 952 F.2d 1384, 1388, 21 USPQ2d 1383, 1387 (Fed. Cir. 1992); Lear Siegler, Inc. v. Aeroquip Corp., 733 F.2d 881, 889, 221 USPQ 1025, 1031 (Fed. Cir. 1984).

The Solicitor states that Glaug did not argue before the Board that Nomura does not show "spaced apart zones," and that Glaug must therefore be prohibited from raising this argument before the Federal Circuit. Glaug responds, and the record shows, that he argued to the Board that "the references teach different structures." The issue of the adhesive structure was before the Board, whose familiarity with the content of the application and the references on which it relies may be assumed by the patent applicant, and need not be repeated as if on appeal to a non-technical court. An applicant's arguments to the PTO examiner and Board are not normally presented in the identical phrases and elaborative lengths that are usually needed in an appeal to the court. It is apparent that the different structures of Glaug's invention and those of the Nomura reference were at issue and were argued before the Board. We thus agree with Glaug that the Nomura reference does not present a prima facie case of obviousness of the placement of the adhesive in Glaug's process.

### ***Claim Clause [i] - The Decay Parameters***

Glaug tabulated, in his specification, comparative data of elastic decay using his system of adhesive zones, as compared with seven commercial brands of training pants. These data showed that the elastic in the pants made by his process exhibited less than half the decay in elasticity, compared with the best of seven commercial brands of training pants. The Board rejected this evidence because Glaug did not describe how the elastic waist was constructed in these prior art pants. The Solicitor argues that these comparative data are not of sufficient quality to overcome the prima facie case of obviousness made by the prior art. On its face, Glaug's data show improvement over these commercial products. These data, included in the specification, are not offered as rebuttal evidence, but as illustrative of an advantageous property of Glaug's training pant as measured by the rate of elastic decay.

Nomura does not suggest that elastic decay would be reduced by spaced placement of the adhesive to provide adhesive-free zones. Thus, Glaug argues, the claim limitation "in which each waist elastic system has an average maximum magnitude of decay less than about 66.67 grams in an extension range of about 175 millimeters to about 300 millimeters over the first three cycles" is neither taught nor suggested by Nomura.

The Board held that the numerical measure of elastic decay in the Glaug claims is simply inherent in any improvement achieved by Glaug through the placement of his adhesive, and does not impart patentability to the claims. While the measurement of a physical property may not of itself impart patentability to otherwise unpatentable claims, when the measured property serves to point up the distinction from the prior art, or advantages over the prior art, that property is relevant to patentability, and its numerical parameters can not only add precision to the claims but also may be considered, along with

all of the evidence, in determination of patentability. See Pall Corp. v. Micron Separations, Inc., 66 F.3d 1211, 1216, 36 USPQ2d 1225, 1228 (Fed. Cir. 1995) (affirming the district court's definition of "skinless" as a performance characteristic in accordance with the measurements of bubble point, flow time, and KL curve); In re Soni, 54 F.3d 746, 750, 34 USPQ2d 1684, 1687 (Fed. Cir. 1995) ("One way for a patent applicant to rebut a prima facie case of obviousness is to make a showing of 'unexpected results,' i.e., to show that the claimed invention exhibits some superior property or advantage that a person of ordinary skill in the relevant art would have found surprising or unexpected.")

### ***The Technical Explanation***

Glaug explained in the specification that his use of spaced adhesive zones "reduc[es] the surface area of joinder between the elastic member and the layer of material [with] a resultant reduction in the elastic member's loss of elasticity." [Application, p.9] The Board stated, and the Solicitor argues, that Glaug's technical explanation of how his invention works establishes that any "intermittently spaced" adhesive would inherently achieve the benefits of the invention. The Board held that this renders the claims obvious because "according to appellants' above-quoted disclosure, this reduction in the surface area of joinder would inherently cause a reduction in the loss of elasticity (decay) of the Nomura elastic members." Bd. op. at 5. Glaug complains that the Board used Glaug's own explanation of his invention against him, instead of citing evidence from the prior art.

An inventor's explanation of how the invention works does not render obvious that which is otherwise unobvious. Since the prior art does not show the spaced zones of adhesive that are provided by Glaug, his teaching that the spacing permits the fabric to bunch and stretch is not evidence of obviousness. If anything, this teaching supports the unobviousness of Glaug's discovery that spacing the adhesive reduces elastic decay so

that the magnitude of decay is as stated in claim clause [i].

### ***Conclusion***

The material facts are generally undisputed. On the entirety of the record we conclude, as a matter of law, that the placement of the adhesive in spaced apart zones generally in the machine direction would not have been obvious in view of Nomura. See Graham v. John Deere, 383 U.S. 1, 17, 148 USPQ 459, 467 (1966) (obviousness is a question of law based on underlying facts).

### ***Claim Clause [f] - The Folded Edge Over the Elastic***

The Magid reference describes a tubular edging of fabric on baby pants to reduce skin irritation. The Board found that this constitutes a folded "hem" which would obviously increase the strength of the edge, and ruled that it would for this reason have been obvious to fold the edge over the elastic of the Glaug training pant.

Glaug states that increased strength of a hem is irrelevant to his process, and points out that Magid does not relate to the adhesive placement. In view of our conclusion that Glaug's adhesive placement establishes patentability of claim 1, we need not consider the effect of the Magid reference.

The decision of the Board is reversed.<sup>1</sup>

REVERSED

---

<sup>1</sup> Glaug does not appeal the rejection of claims 12 to 25 for obviousness-type double patenting. That rejection is not affected by our decision.